

MANUAL

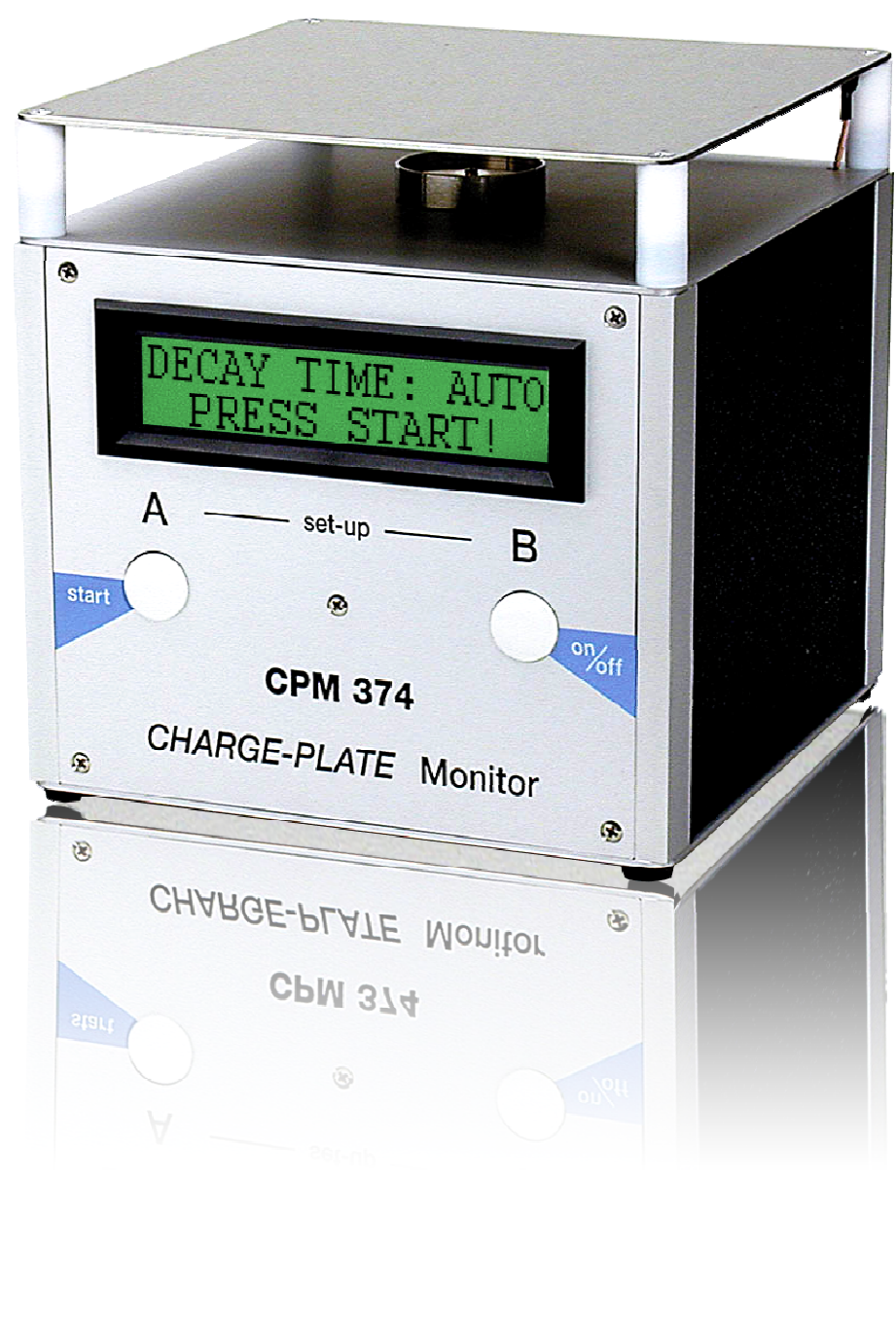

Charge Plate Monitor CPM 374

Inhalt

1. Product Description	3
1.1. Specifications.....	3
1.2 Legend	4
2. Initial Operation.....	5
3. Mode Selection	5
4. Charge Plate Mode	5
4.1. Decay Time and Offset Voltage	5
4.2. Saving Data.....	7
4.2.1. Choose Storage Space.....	8
4.3. Settings.....	8
4.3.1. Setup.....	8
4.3.2. Calibration.....	10
5. Voltmeter Mode	11
5.1. Voltage Metering.....	11
5.2. Setting up the Measurement Range	11
5.3. Settings.....	11
5.3.1. Change distance	11
5.3.2. Zero Adjust.....	12
6. Electrostatic Field Meter Mode.....	13
6.1. Metering an Electrostatic Field.....	13
6.2. Adjust Range.....	13
6.3. Zero Adjust.....	13
7. Further Messages	13
8. Warranty.....	14
9. Grounding.....	14
10. Warning Notices.....	14
11. Maintenance and Calibration.....	15
12. Important Information.....	15
13. Scope of Delivery	15

1. Product Description

The Charge Plate Monitor CPM 374 with its built-in timer function consists of a high voltage unit and an electrostatic field meter. Therefore it has an input resistance of $10^{16}\Omega$ and is suited for measuring static potentials and discharging times of air ionizers.

The CPM 374 corresponds to DIN EN 61340-5-1 and EOS/ESD S.3.1.

For measuring vertically the enclosed distance bolts have to be used.

Important: The high voltage unit is protected by high impedance and therefore touch-proof.

By the use of battery power and its compact design the CPM 374 is perfectly suited for mobile application. Of course it can be operated by using the provided wall power supply. As the CPM 374 is menu-driven and operated by 2 pushbuttons the device is very user-friendly. For a better orientation the selected parameters are displayed in the double-spaced LCD display.

The device can be operated computer-controlled by use of the provided Excel software.

1.1. Specifications

Dimensions (L x W x H):	152mm x 152mm x 152mm
Weight:	Approx. 1,5kg
Display:	Alpha-numeric display (100mm x 24mm) 2 lines with 16 digits each
Measurement ranges:	Charge Plate: Voltage potentials up to $\pm 1000V$ Voltmeter (MK11): Voltages up to $\pm 2000V$ Static field meter: El. DC fields up to $\pm 200kV/m$
PC-Interface:	Serial port, 9-pol. Sub-D connector
Battery:	7,2V / 1300mAh
Time of operation:	Approx. 4h on continuous duty with fully charged battery
Charging time:	Max. 14h
Wall power supply:	Prim. 230V / 50Hz, sec. 12V DC / 750mA
Current consumption:	Max. 600mA, battery powered max. 150mA
Temperature range:	0...40°C
Humidity:	10...60% humidity

1.2 Legend

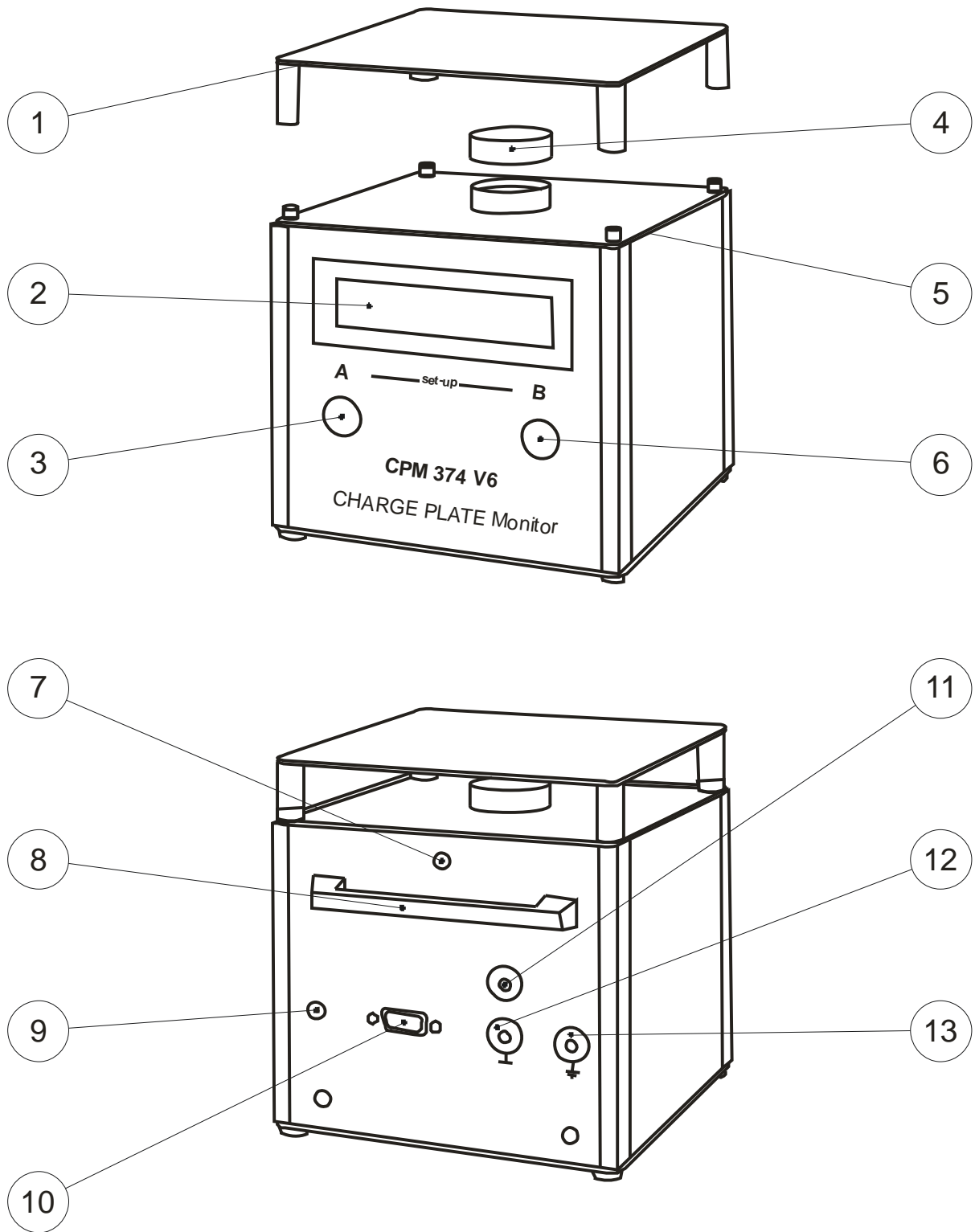

- 1 Plate electrode
- 2 LCD-Display
- 3 Button «A»
- 4 Protective cap
- 5 Modulator system
- 6 Button «B»
- 7 Thread for spacers

- 8 Handhold
- 9 Mains connection 12V DC
- 10 Serial interface
- 11 ±1V analog output with banana jack
- 12 Ground jack
- 13 Ground jack

2. Initial Operation

With its integrated NiMH storage battery the CPM 374 is plug-and-play. After switching on the software version is displayed briefly.

Please use only the provided power supply. In battery operation mode the backlight is powered off to save power. Furthermore the device has automatic power shut-off after 10min of inactivity.

3. Mode Selection

The CPM 374 can be driven as charge plate monitor, voltmeter or electrostatic field meter. By pressing button «B» the modes can be switched.



4. Charge Plate Mode

4.1. Decay Time and Offset Voltage

The display shows the selected type of measurement and prompts to start, e.g.:

DECAY TIME: AUTO

PRESS START !

The last mode is stored in the EEPROM and displayed after turning on.

By selecting *Decay Time = AUTO* the decay time for the positive and the negative voltage is determined automatically. *AUTO* is recommended because the Start button has to be pressed only once to perform a measurement, including the determination of the offset voltage.

The **offset voltage** is the plate's potential after a certain time that defines the equilibrium of positive and negative ions. If the offset voltage is positive, the air ionizer has an excess of positive ions – in case of negative offset voltage the air ionizer excesses negative ions.

Please consider the manufacturer's instructions for a qualitative analysis.

After pressing the button «A», the plate electrode is charged by the integrated high voltage unit. The display shows the timer parameters and the applied voltage, e.g.:

TIMER: 1000-100V

U > 1200V

The timer starts by passing the upper threshold (1000V in the example)

TIMER = XX.Xs

U = XXXXV

and determines the decay time by reaching the lower threshold (100V in the example). The parameters for the timer can be selected in the **Setup**.

Important: Decay times $\leq 0,1s$ are displayed as $<0,1s$

After the determination of the decay time (s), the offset voltage is measured after a defined time period.

OFFSET = XXXs

U = XXXXV

The measurement is finished after determining the offset voltage. All data required, e.g. to qualify an air ionizer, can be read off the display. The offset voltage *UOFF* and the associated time slice are displayed in the upper line, the decay time is displayed in the bottom line as *POS.DECAY* or *NEG.DECAY* or ii *AUTO - Mode* alternating every second:

OFF = XXXV T = XXXs

POS.DECAY = XX.Xs

The display remains until button «A» *Continue* is pressed.

4.2. Saving Data

It is possible to save the measured data in the internal memory. After every measurement the device prompts :

SAVE VALUES?
A<YES **NO>B**

By pressing button «**B**» the current data are discarded and the next measurement can be performed.

By pressing button «**A**» the saving is initiated. In event of free space section 4.2.1 is displayed. In the case of full memory (99 entries) the device announces for 2s:

MEMORY FULL!

To save the data nevertheless the memory has to be erased. Therefore the following prompt is displayed:

DELETE FILES?
A<YES **NO>B**

Skip the deleting process by pressing button «**B**» and continue to the next measurement. The last result disappears from the display and cannot be saved.

Important: It is strongly recommended to copy all data with the provided software to a pc. In this case the memory can be erased without losing precious data.

After erasing the whole memory by pressing button «**A**», the device proposes the storage space *FILE NO: 01* for saving the last measurement.

4.2.1. Choose Storage Space

In case of enough free space the device prompts:

FILE NO: XX	
A<YES	CHANGE>B

Confirm the selection by pressing «A». The data is stored:

PLEASE WAIT !	
SAVING !	

The selection can be modified by pressing button «B». The device displays:

FILE NO: XX	
A<-10	-1>B

Decrease the tens column by pressing «A» and/or decrease the ones column by pressing «B».

Important: Only existing file numbers can be overwritten.

If no button is pressed for about 3s the display returns and you can select the new value by pressing button «A».

4.3. Settings

By pressing «A» and «B» simultaneously the device prompts after 1s:

SET-UP ?	
A<YES	NO>B

Press «A» to enter *SETUP* or «B» followed by «A» to enter the *ZERO ADJUST* menu.

4.3.1. Setup

In the *SETUP* the last selected settings for mode are displayed:

MODE = AUTO	
A<OK	CHANGE>B

By pressing «B» the following options can be selected:

AUTO
POS.
NEG.
AUTO
...

In the modes *POS* or *NEG* only positive resp. negative decay time is measured and after the time period the offset voltage is displayed.

Afterwards the starting voltage can be set

START: U = 1000V
A<OK **CHANGE>B**

Confirm the displayed value by pressing «A» or press «B» to select a new one. Values are switched in the following order:

500V > 550V > ... > 950V > 1000V > ...

Next the stop voltage is set:

STOP: U = 100V
A<OK **CHANGE>B**

Confirm the displayed value by pressing «A» or press «B» to select a new one. Values are switched in the following order:

0V > 50V > ... > 450V > 500V > ...

Afterwards the time period for the offset voltage measurement is inquired:

OFFSET: 10s
A<OK **CHANGE>B**

Confirm the displayed value by pressing «A» or press «B» to select a new one. Values are switched in the following order:

0s > 10s > ... > 1min > ... > 10min

The selected parameters for *START*, *STOP* and *OFFSET* are displayed for 3 seconds:

TIMER: 1000-100V
OFFSET: 1 min

The device inquires whether the parameters are right:

TIMER + OFFSET OK?
A<YES **NO>B**

Confirm the displayed value by pressing «A» or press «B» to change the values again.

After pressing button «A» the device inquires if the memory should be cleared:

CLEAR MEMORY?
A<YES **NO>B**

Important: If you have changed the parameters, the memory **must be cleared** to apply the changes, because stored data always include the stored parameters.

Delete all files and apply the new parameters by pressing button «A» Setup will quit afterwards.

PARAMETER
CHANGED

Press button «B» to discard the changes:

PARAMETER
NOT CHANGED !

The old parameters are set again and the changes that have been made are discarded.

4.3.2. Calibration

By pressing «B» followed by «A» after the *SETUP* question, the calibration menu appears:

ZERO ADJUST?
A<YES **NO>B**

Choose «A» *YES* to perform an auto offset calibration. The device returns:

PLEASE WAIT!
CALIBRATION!

Pressing «B» skips the calibration.

Caution: During the calibration external voltage must not be connected to the plate electrode!

5. Voltmeter Mode

5.1. Volt Meter

For metering voltages with the CPM 374 the plate electrode has to be removed. Afterwards the voltage measuring head MK11 has to be mounted on the modulator system of the integrated electrostatic field meter.

5.2. Setting up the Measurement Range

Information on changing the mode is available in section 3. In the voltmeter mode the display shows:

V-METER R=2kV	
MK11!	U = 0,00kV

By pressing «A» the following ranges can be set:



The display shows the current range, in the example above $R=2kV$.

5.3. Settings

After pressing «A» and «B» simultaneously the device prompts after 1s:

SET-UP?	
A<YES	NO>B

Enter the *SETUP* by pressing «A» or *ZERO ADJUST* by pressing «B» followed by «A».

5.3.1. Change Mode

In the *SETUP* the following message appears:

SELECT Mode?	
A<YES	NO>B

After pressing «A» to change the mode the device prompts:

V-Mode:	MK11!
A<OK	CHANGE>B

By pressing button «B» the following options can be set:

V-Mode:	Plate!
A<OK	CHANGE>B

Confirm the selection and exit *SETUP* by pressing «**A**». Mount the selected part (Mk11 or Plate) on the system. The result is displayed in Volts for the selected part.

5.3.2. Zero Adjust

If you press button «**B**» for *NO* in 5.3 Settings the device asks for a zero adjust:

ZERO ADJUST ?	
A<YES	NO>B

Press «**A**» for a zero adjust or «**B**» to leave the menu. After pressing «**A**» the prompts whether MK11 or Plate is installed:

MK11 FIXED ?	
A<YES	NO>B

For a proper zero adjust the measuring head has to be grounded:

GROUND MK11 ?	
A<YES	NO>B

Ground the measuring head and confirm that by pressing button «**A**». Afterwards the zero adjust is performed and the device returns:

PLEASE WAIT !	
CALIBRATION !	

Important: During the zero adjust external voltage must not be connected to the device or the measuring head, because otherwise no proper zero adjust can be performed.

To perform a zero adjust without MK11 please mount the protective cap and confirm this as grounded MK11 in the menu.

By mounted Plate it is asked if the plate is free ? Then the plate is grounded internal !

6. Electrostatic Field Meter Mode

For operation in electrostatic field meter mode the upper plate has to be removed. **No** measuring head may be installed.

6.1. Metering an Electrostatic Field

Only static (DC) fields can be measured with the integrated electrostatic field meter¹. The display directly shows the electric field strength in (kilo)Volt/meter:

EFIELD R=20kV/m E = 0,0kV/m
--

6.2. Adjust Range

By pressing button «A» the selected range can be changed. You can choose between the following options:

5kV/m
>
20kV/m
>
50kV/m
>
200kV/m

6.3. Zero Adjust

The provided protective cap has to be mounted on the modulator system to perform a zero adjust. After pressing «A» and «B» simultaneously for about 1s the device asks whether a zero adjust should be performed:

ZERO ADJUST ?	
A<YES	NO>B

Quit by pressing button «B» or press «A» *YES* to advance. The device asks to put on the protective cap:

PUT ON COVER ?	
A<YES	NO>B

Put the protective cap on the modulator system and press «A» to perform the zero adjust. Pressing button «B» closes the menu.

7. Further Messages

In case of a damaged electrostatic field meter the device displays:

¹ Frequenz $f < 1\text{Hz}$

EFM DEFECT !
REPAIR IS NEEDED

If the supply voltage of the NiMH battery falls below 6.7 Volt, the device returns in the upper line:

LOW BATTERY !

The battery has to be charged, although the current measurement can be completed.

Important: Please use only the provided power supply to charge the battery. Charging also takes place while the device is switched off. The maximum charge time for the switched off device is about 14 hours.

If the supply voltage falls below 6.4 Volt, the display shows

AUTO OFF
LOW BATTERY !

before the device powers off automatically to prevent total discharge of the battery. Total discharge can lead to damage or breakdown of the battery!

8. Warranty

In case of proper operation according to the manual we issue a guarantee of 24 months. Mechanical damage and battery destruction by wrong handling are excepted.

Guarantee expires on opening the device!

9. Grounding

To provide accurate evidence of the polarity and magnitude of the field measured, the device has to be grounded properly. To this end connect the instrument at the grounding jack with ground.

10. Warning Notices

- The instruments are not accredited for measurements in explosion-proof areas. Measurements in power plants are not permitted!
- Alternating fields $f > 1$ Hz cannot be measured
- Spark discharge on the modulator system must be avoided
- Do not connect the switched off device to the mains adapter for longer periods (max. 14h), overloading may occur

1)

11. Maintenance and Calibration

The PTFE spacers need to be kept clean (free of grease), therefore should not be touched by hand. If the voltage decrease under normal surrounding conditions without ion source is larger than 100V/min, the spacers have to be cleaned with acetone or comparable.

The recommended calibration interval is 1 year

12. Important Information

During air ionization measurements please note :

As the plate electrode is insulated it has to be protected from electrostatic induction. Electrostatic induction can be effected by a person passing by or by moving a charged object close to the instrument. External static fields caused by high charges in the instruments surrounding have to be avoided.

13. Scope of Delivery

The charge plate monitor CPM 374 is delivered with:

- Charge Plate Monitor CPM 374
- Conductive transport case
- Wall power supply prim. 230V/50Hz sec. 12V DC/750mA
- Voltage measuring head MK11
- PTFE measuring line 1m
- Alligator clip
- Grounding cable
- Serial PC cable
- 3 spacers
- Manual
- Declaration of factory calibration
- CD with Excel software and manual

